

# 63W LED WORK LIGHT



## FEATURES & BENEFITS

The MLB-63W LED offers outstanding light output in a functional design which can be easily adjusted, with either of the supplied trunnion or single bolt bracket options. High quality construction and components enable to withstand vibration up to 21Grms. Built-in reverse polarity protection helps prevent accidental damage caused by incorrect installation.

Electronic thermal management ensures that if the light is subjected to a massive heat overload, that a self protection protocol is engaged to reduce the light output, until such time as the heat overload retreats to normal parameters.

MLB LED work light range is a high quality, versatile range designed for Industrial applications such as rigid truck bodies, utility vehicles, emergency & rescue vehicles, cranes and more.

## DIMENSIONS

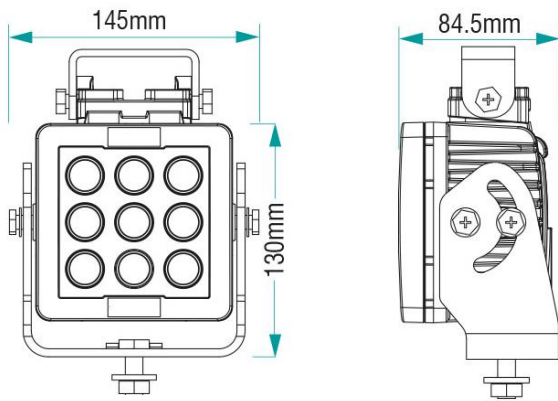

## SPECIFICATIONS

Wattage	63 W
LEDs	9 x 7W Cree
Light Color Temp	5,700 K
Effective / Raw Lumens	5,734 lm / 7,200 lm
Voltage	9-32 VDC
Amperage	5.26 A @ 12V
Connector	Deutsch DT04-2P
Bracket Type	Trunnion & Single Bolt
Weight	1.8 kg
Dimensions WxHxD	145 x 130 x 84.5 mm
IP Rating	IP69K
Vibration Rating	21.2 Grms
EMC Approval	CISPR25 Class 1 / CE Approved
Lens Material	5 mm Polycarbonate
Housing Material	Aluminum
Housing Coating	Marine Grade Anti-Corrosive

## BEAM PATTERNS



MLB-63-25

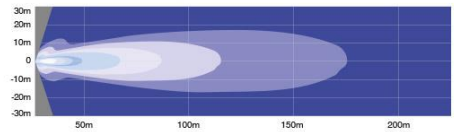

MLB-63-40

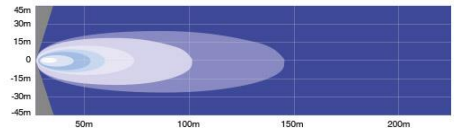

MLB-63-60

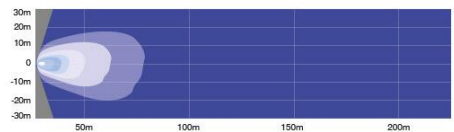

MLB-63-90

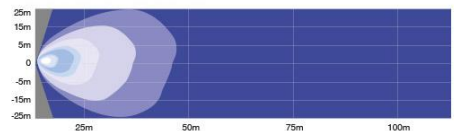

MLB-63-E

