

# 35W LED WORK LIGHT

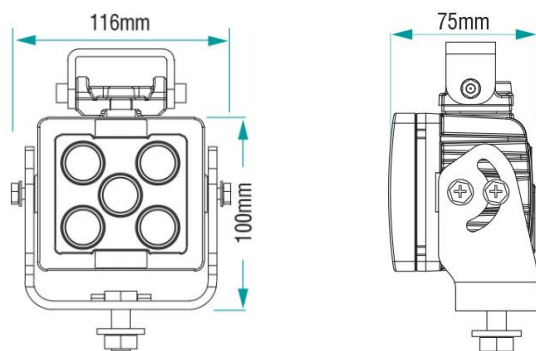

## DIMENSIONS



## SPECIFICATIONS

|                        |                               |
|------------------------|-------------------------------|
| Wattage                | 35 W                          |
| LEDs                   | 5 x 7W Cree                   |
| Light Color Temp       | 5,700 K                       |
| Effective / Raw Lumens | 3,305 lm / 4,000 lm           |
| Voltage                | 9-32 VDC                      |
| Amperage               | 3.3 A @ 12V                   |
| Connector              | Deutsch DT04-2P               |
| Bracket Type           | Trunnion & Single Bolt        |
| Weight                 | 1.0 kg                        |
| Dimensions WxHxD       | 116 x 100 x 75 mm             |
| IP Rating              | IP69K                         |
| Vibration Rating       | 21.2 Grms                     |
| EMC Approval           | CISPR25 Class 1 / CE Approved |
| Lens Material          | 5 mm Polycarbonate            |
| Housing Material       | Aluminum                      |
| Housing Coating        | Marine Grade Anti-Corrosive   |

## FEATURES & BENEFITS

The MLB-35W LED offers outstanding light output in a compact design which can be easily adjusted, with either of the supplied trunnion or single bolt bracket options. High quality construction and components enable to withstand vibration up to 21Grms. Built-in reverse polarity protection helps prevent accidental damage caused by incorrect installation.

Electronic thermal management ensures that if the light is subjected to a massive heat overload, that a self protection protocol is engaged to reduce the light output, until such time as the heat overload retreats to normal parameters.

MLB LED work light range is a high quality, versatile range designed for industrial applications such as work bodies, utility vehicles, emergency & rescue vehicles, forklifts and more.

## BEAM PATTERNS

