

12W LED WORK LIGHT



FEATURES & BENEFITS

The **MLB 12W LED** offers outstanding light output in a small, compact design which can be installed at the desired orientation, with either of the supplied trunnion or single bolt bracket options.

High quality construction and components enable the LED to withstand vibration up to 21Grms. Built-in reverse polarity protection helps prevent accidental damage caused by incorrect installation.

DIMENSIONS

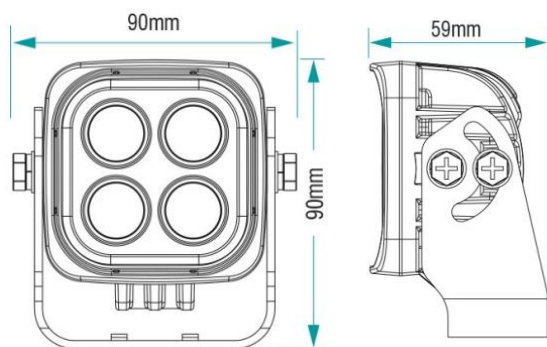

BEAM PATTERNS

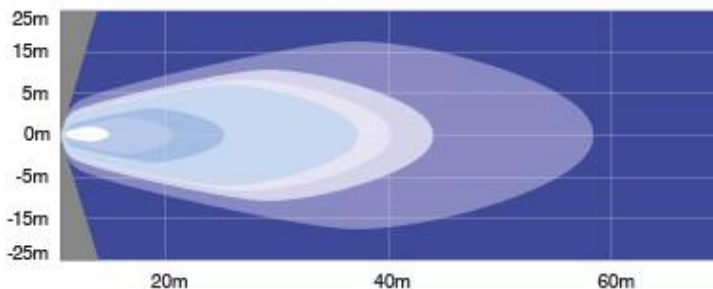

MLB-12-60: 60° Extra Wide Beam Pattern

SPECIFICATIONS

Wattage	12 W
LEDs	4 x 3W Cree
Light Color Temp	6,000 K
Effective / Raw Lumens	950 lm / 2,000 lm
Voltage	9-32 VDC
Amperage	1.0 A @ 12V
Connector	Deutsch DT04-2P
Bracket Type	Trunnion & Single Bolt
Weight	0.48 kg
Dimensions WxHxD	90 x 90 x 59 mm
IP Rating	IP69K
Vibration Rating	21.2 Grms
EMC Approval	CISPR25 Class 1 / CE Approved
Lens Material	Polycarbonate
Housing Material	Aluminum
Housing Coating	Marine Grade Anti-Corrosive

