

MERLIN[®]

LED MARINE LIGHTING SOLUTIONS



Catalogue 2017

Merlin Equipment Pte Ltd
40 Tech Park Crescent, Singapore 638097
Tel: +65 6863 1753 Fax: +65 6863 1757
Email: sales@merlinequip.com



MARINE LED LIGHTING SOLUTIONS

CONTENTS

INTRODUCTION	03
Testing	03
LED Technology	04
LED LIGHT	06
LED LIGHTBAR	07
HEAVY INDUSTRIAL	09
MLBMAR 140/84 W	10
MLBMAR 63/35 W	11
MARITIME SOLUTIONS	12
MLP Series	15
MLR Series	16
MLES Series	17
ACCESSORIES	18

QUALITY AS A PRIORITY PRODUCT TESTING

CONSUMPTION RANGE



All products are put on a digital power meter to test that it is consuming the correct amount of power, checking for any electrical faults.

LONG TERM DURABILITY

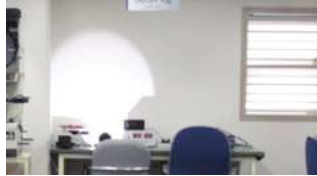

Products are then switched on and off 20,000 times repeatedly to ensure that they remain functional after all testing.

SUBMERSION/AGING



Once products are assembled every product is run through a submersion (water dunk test), then placed onto an aging rack and powered up for 30 minutes.

THERMAL IMPACT



Products are placed in a -40°C chamber for 30 minutes, and then placed in a 80°C chamber for an additional 30 minutes. Products are then left on for 72 hours.

PHOTOMETRIC



Lights are tested in the Gonio photometer to model the beam pattern and depict the overall light output.

TEMPERATURE AND HUMIDITY



Products are placed in a 60°C, 94% humidity chamber and left operational for 72 hours. Afterwards, products are inspected for moisture and damage.

INGRESS



Products are sprayed from close distances with 80~100 BAR water pressure to verify the Ingress Protection rating, ensuring they are sealed properly.

VIBRATIONS



Products are placed on the vibration shock for 4 hours to test that they can withstand the rated vibration standard. Products tested at 60 Grms are performed off-site.

HIGH LEVEL CERTIFICATIONS

PHOTO BIOLOGICAL

IEC 62471 Ensures that light output has safe levels of UV exposure for both skin and eyes.

E-MARK

European Regulatory certification for on highway use.

ROHS

RoHS Ensures no use of restricted hazardous material in products such as lead, mercury, cadmium, PBB, PBDE and Phthalate.

ADR 13/00

Products which are in compliance with the Australian Design Rules (ADR).

DOT

US Department of Transportation certified for on road use.

IP RATING

IP-69K Ingress Protection rates protection against outside elements. First number is solids, second is liquids.

UL

UL Certification is recognized around the world as a way to ensure standards.

CE

CE is a mandatory conformity mark for products in the European Economic Area.

ATEX (94/9/EC)

The ATEX 94 certification is given to electronic equipment that is resistant to flame and explosion.

EMC

EMC and EMI certifies that a product does not interfere with other electrical products. This includes CISPR 25 Certifications

LED TECHNOLOGY EXPLAINED

LED



Our LED lighting runs at 6000K temperature for intense, bright white light for maximum visibility and safety. LED Lights don't use a bulb, making them much more durable than other options.

INTENSITY



AMP DRAW



LUMENS PER WATT



HID



Our HID lighting runs at 5000K temperature a super white beam color. HID required a bulb, starter and ballast to operate. They have a higher output per wattage than halogen bulbs.

INTENSITY



AMP DRAW



LUMENS PER WATT



HALOGEN



We offers a number of different Halogen Lighting options. The Tungsten-Halogen series use an oversized globe and specially engineered filament to enhance light output. We offers many headlight replacement.

INTENSITY



AMP DRAW



LUMENS PER WATT



WHAT MAKES OUR LEDS DIFFERENT

TOP BINNING

Not all LEDs are created equal. Each run of LEDs by the manufacturer is binned to classify the quality within that batch. We uses only top-binned LEDs to ensure the highest quality.

WEATHERPROOF DEUTSCH CONNECTORS

Each product features a weatherproof deutsch connector, ensuring the functionality of the light in harsh conditions. The manufacturer test each batch of lights to make sure its resistant to weather.

HIGH EFFICACY

Our products are engineered for the highest possible luminous efficacy – the ration of lumens per watt.

PULSE WIDTH MODULATION

When enabled, Pulse Width Modulation integrated circuitry flashes the LED faster than human eye can see for reduced heat, prolonged LED life and dimming capabilities.

ELECTRONIC THERMAL MANAGEMENT

Integrated Electronic Thermal Management automatically regulates heat levels by engaging ETM to prolong each LEDs lifespan to 50,000 hours.

DIMMING CAPABILITY

Prime Drive includes dimming capacity. Dimming works by engaging PWM to reduce power white maintaining steady output. We offers push button and dial dimmer units.

LED TYPES

90 WATT LED

The MLC-90 housing features a 90 Watt LED. Combined with IRIS Reflector Technology, this allow for 1,000 meters of usable light.

10 WATT LED

The benefits of the 10 watt LED are great intensity and bulk lighting. The 10 watt LED provides the greatest bulk lighting on the market.

3 WATT LED

The benefits of the 3 watt LED are great output and beam precision. The tight footprint allows for precision optical control.

50 WATT LED

The MLC-50 housing features a 50 Watt LED. Combined with IRIS Reflector Technology, this allow for 750 meters of usable light from a single LED.

7 AND 6 WATT LED

Utilizing the same footprint as the 5 watt, 7 and 6 watt LED lights have an increased luminous efficacy over 5 watt LEDs. Producing up to 50% more light than 5 watt.

SMD LED

The Surface Mounted Diode (SMD) is used in MLSW fixture and MLUF to create an even, ultra wide beam pattern for area lighting applications.

25 WATT LED

The MLC-25 housing features a 25 Watt LED. Combined with IRIS Reflector Technology, this allow for 300 meters of usable light.

5 WATTS LED

Utilizing the same footprint as the 3 watt, but at twice the output, the 5 watt LED combines the advantages of a tight LED footprint with the ultimate output.

STRUCTURAL LED

Ideal for structural applications because of the 117 lumen per watt ratio. We're able to get more light output for a lower cost than standard LEDs.

USABLE LIGHT



Usable light is defined as the light that is actually converted for use in forward projection lighting. We measure this by accounting for effective, rather than raw, lumens in our calculations. We also provide the measurement of distance at which a light achieves one lux. One lux is the level of light needed to read a newspaper. We provide lumen ratings in effective lumens, which factors in the levels of optical, electrical and heat loss. This states the true output of the light as a whole, not just a single component such as the LED.

ISOLUX CHART

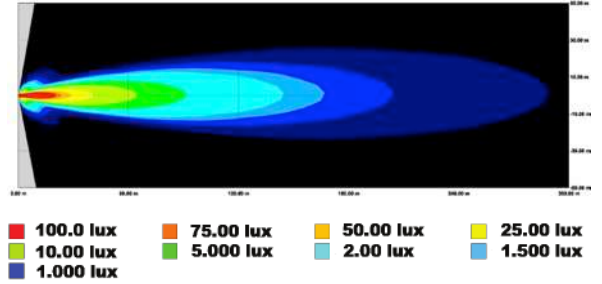

Measuring Lux

On our lux charts, the different colors within a light's beam on the lux chart correlates to a different lux level at that distance from the source, according to the colors above.

TOTAL LIGHT OUTPUT = LUMENS

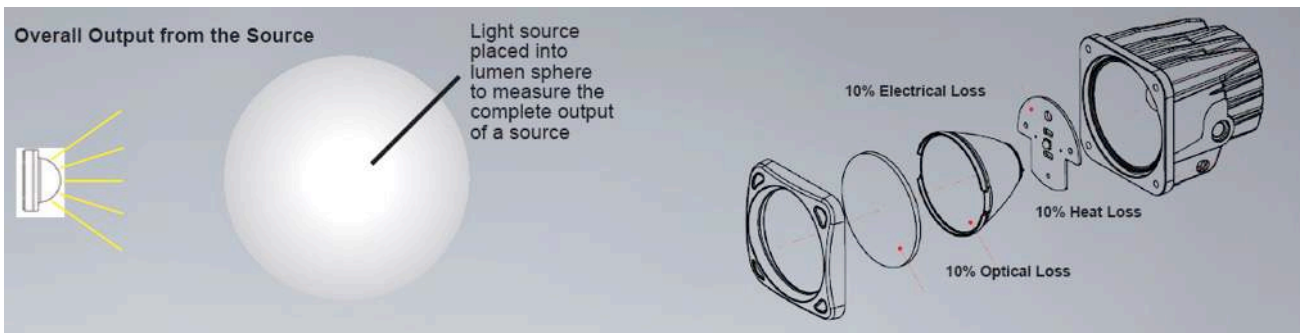

Raw Lumen Output

Lumens are a common standard for measuring light output at the source. It is important to know that the lighting source manufacturer rating is only for the light source and does not account for losses due to optical inefficiencies, electrical inefficiencies or heat.

Effective Lumen Output

The sheer output of the light source is not enough to capture the whole story. When rating the effective output of a light source, the light lost as heat, in optical light spray and electrical inefficiency must also be accounted for, as each of these reduce the total usable lumens.

LIGHT AT SPECIFIC POINT = LUX AND FOOT CANDLES

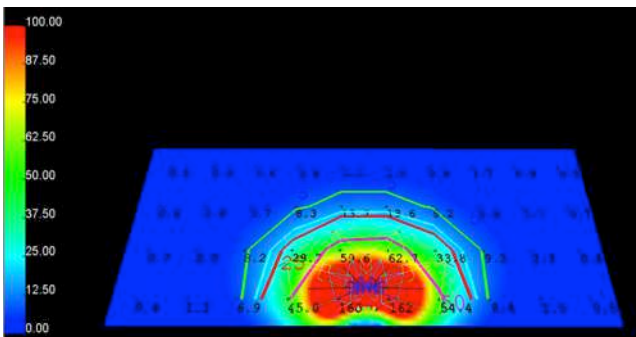

Lux

Lux measures the amount of light per square meter. Unlike lumens which measures light at the source, lux is measured at a specific area. This helps better determine whether those effective lumens are lighting up the environment with the necessary light.

Foot-Candles

Foot Candle measures the amount of light per square foot, as opposed to square meter as with lux. Foot-Candle and lux are interchangeable, with 100 lux = 10.42 foot-candles.

BEAM PATTERNS ILLUSTRATED

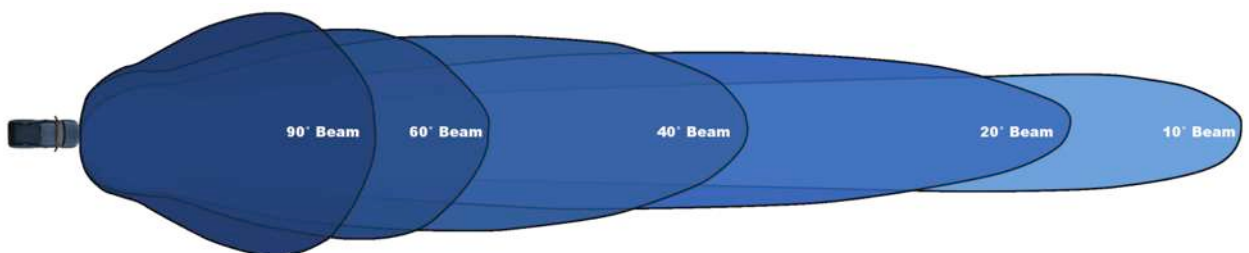



LED LIGHTS

MLCMAR 25 W



25-WATT SINGLE SOURCE LED PRODUCES 300m OF USABLE LIGHT
 Lightweight Hybrid Housing / Long Range IRIS Reflector / Snap-On Covers Change Beam Pattern

BEAM PATTERN 10°	WARRANTY Extended	DIMENSIONS 120 x 147 x 110 mm
RAW LUMENS 2,500 lm (ea)	DISTANCE TO 1 LUX 300 m	INCH 4.72" x 5.75" x 4.35"
WATTAGE / AMPS 25 W / 11.66 A @12V	VIBRATION RATING 60 Grms	WEIGHT 0.92 kg



BEAM PATTERN MLCMAR-25-10



0m 200m 400m
 | 1002' Distance at 1 lux

75m
 45m
 15m = 59' Spread
 -15m at 1 lux
 -45m
 -75m

2D VIEW

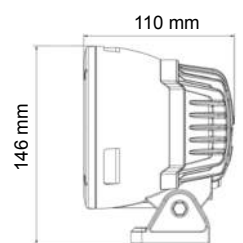



LED LIGHT BARS

LED Light Bars come in a variety of sizes from 10cm all the way to 130cm. Our LED Light Bars have an extruded 6061 aluminium housing and are created from top-binned, perfectly crafted LEDs for a durable and highly effective LED lighting solution.

MLLB-XPMAR SERIES



BRIGHTEST LIGHT BAR ON THE MARKET

- Full Range in Road Way
- Plug and Play Harness Included
- PWM Integrated Dimming Circuitry
- 90% Efficiency Thermal Management & Dimming

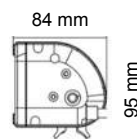

REFERENCE	WATTS	LED	LENGTH	WEIGHT	AMP DRAW	RAWS LUMENS	EFFECTIVE LUMENS	BEAM PATTERN
MLLB-XPMAR-60	60	12	201 mm	2.4 kg	5 A	6,336 lm	4,440 lm	MIXED
MLLB-XPMAR-90	90	18	282 mm	3.0 kg	7.5 A	9,504 lm	6,660 lm	MIXED
MLLB-XPMAR-180	180	36	525 mm	4.8 kg	15 A	19,008 lm	13,320 lm	MIXED
MLLB-XPMAR-270	270	54	768 mm	6.6 kg	22.5 A	28,512 lm	19,980 lm	MIXED
MLLB-XPMAR-360	360	72	1,011 mm	8.4 kg	30 A	38,016 lm	26,640 lm	MIXED

MLLB-SMAR SERIES



EXTREM OUTPUT IN A COMPACT LIGHT BAR

- Sleek Low Profile Design
- 90% Efficiency Next Gen LED
- Plug and Play Harness Included
- PWM Integrated Dimming Circuitry
- Electronic Thermal Management & Dimming

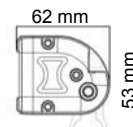

REFERENCE	WATTS	LED	LENGTH	WEIGHT	AMP DRAW	RAWS LUMENS	EFFECTIVE LUMENS	BEAM PATTERN
MLLB-SMAR-15	15	3	118 mm	0.5 kg	1.25 A	1,584 lm	1,110 lm	10° or 40°
MLLB-SMAR-30	30	6	214 mm	0.9 kg	2.5 A	3,168 lm	2,220 lm	10° or 40°
MLLB-SMAR-45	45	9	310 mm	1.3 kg	3.75 A	4,752 lm	3,330 lm	10° or 40°
MLLB-SMAR-75	75	15	502 mm	2.0 kg	6.25 A	7,920 lm	5,550 lm	10° or 40°
MLLB-SMAR-120	120	24	790 mm	2.7 kg	10 A	12,672 lm	8,880 lm	10° or 40°
MLLB-SMAR-135	135	27	886 mm	3.5 kg	11.25 A	14,256 lm	9,990 lm	10° or 40°
MLLB-SMAR-165	165	33	1,078 mm	4.2 kg	13.75 A	17,424 lm	12,210 lm	10° or 40°
MLLB-SMAR-195	195	39	1,270 mm	4.9 kg	16.25 A	20,592 lm	14,430 lm	10° or 40°

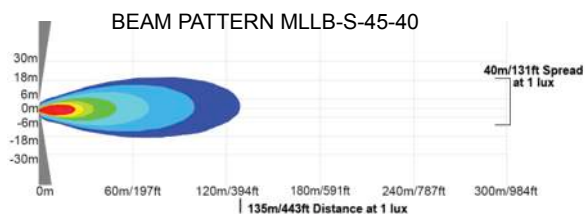
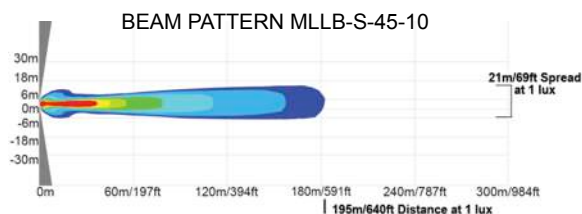

MLLB-XPMAR SERIES



BRIGHTEST LIGHT BAR ON THE MARKET

- Full Range in Road Way
- Plug and Play Harness Included
- PWM Integrated Dimming Circuitry
- 90% Efficiency Thermal Management & Dimming

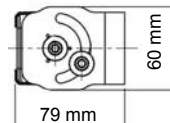

REFERENCE	WATTS	LED	LENGTH	WEIGHT	AMP DRAW	RAWS LUMENS	EFFECTIVE LUMENS	BEAM PATTERN
MLLB-SMAR-45	45	9	353 mm	1.9 kg	3.7 A	4,752 lm	3,330 lm	10° or 40°
MLLB-SMAR-60	60	12	448 mm	2.7 kg	5.0 A	6,666 lm	4,440 lm	10° or 40°
MLLB-SMAR-90	90	18	640 mm	2.8 kg	7.5 A	9,504 lm	6,660 lm	10° or 40°

MARINE HEAVY INDUSTRIAL

MARINE GRADE - ANTI CORROSIVE COATING

MLB Series lights polyester powder coating is designed for the exterior environment offering excellent long term light and either resistance. Its marine grade anti-corrosive coating has passed multiple chemical and durability tests including; Salt Spray AS3715 2.5.10 (1000 hours), Exterior durability AS3715 (12 months continuous exposure)

OUTSTANDING LIGHT OUTPUT

The latest LEDs provide a mass volume of light where you need it most. The colour temperature of LED is closer to that of sunlight which reduces eye strain and enables excellent peripheral vision.

MOULDED DT CONNECTORS

Any product is only as good as its components and Deutsch's moulded DT connectors are manufactured from high quality materials selected for their ability to withstand years of environmental exposure.

ELECTRONIC THERMAL MANAGEMENT

In an extraordinary situation where the light is subjected to massive heat overload, a self protection protocol is engaged to reduce the light output, until such time as the heat overload retreats to normal parameters.

LONG LIFE - 50,000 Hours

Using Pulse Width Modulation (PWM), the LEDs are being turned on and off at a frequency quicker than the human eye can detect. This technology allows the LEDs to be driven hard whilst still achieving a long life span of 50,000 hours.

CISPR - Class 1 Rated*

To limit the RF noise that your work light introduces into electronics/radios, enabling better communication.

IP69K RATED

The IP69K rating ensures that the work lights are dust tight with no ingress of particulates and protected against high pressure, high temperature wash downs.

REVERSE POLARITY PROTECTION

BT Series lights will not sustain accidental damage if the polarity to the light is reversed by incorrect installation.



ABOUT THE MLBMAR MARINE HEAVY INDUSTRIAL SERIES

UPGRADED STAINLESS STEEL TRUNNION BRACKET FOR MINING

The MLBMAR Marine Heavy Industrial Series offers outstanding light output in a functional design utilizing a forward rake trunnion bracket, with integrated aiming markings on the sides and base of the bracket. Utilizing the aiming system in conjunction with 3D fit outs to ensure the correct light for any environment. As well as increasing safety, be keeping light out of other operators. High quality construction and components enable the MLBMAR Marine Heavy Industrial Series to withstand vibration up to 60Grms. Built-in reverse polarity protection helps prevent accidental damage caused by incorrect installation. Electronic thermal management ensures that if the light is subjected to massive heat overload, that a self protection protocol is engaged to reduce the light output, until such time as the heat overload retreats to normal parameters.

MLBMAR 140 W



400 / 500 WATT METAL HALIDE REPLACEMENT FIXTURE
 Forward Rake Trunnion Bracket / Aiming System on Bracket / Reverse Polarity Protection

BEAM PATTERN 10°,25°,40°,60°,90°,30x65°	WARRANTY Extended	DIMENSIONS 239 x 173 x 125 mm
RAW LUMENS 16,000 lm (ea)	EFFECTIVE LUMENS 11,270 lm (ea)	INCH 9.42" x 6.81" x 4.92"
WATTAGE / AMPS 140 W / 11.66 A @12V	VIBRATION RATING 60 Grms	WEIGHT 4.2 kg



MLBMAR-140-10

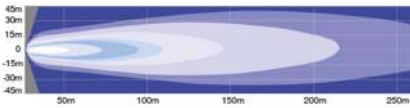

MLBMAR-140-40

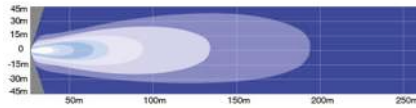

MLBMAR-140-90

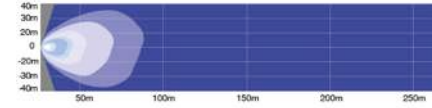

MLBMAR-140-25

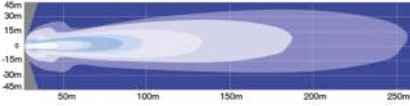

MLBMAR-140-60

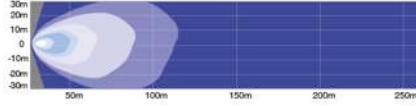

MLBMAR-140-E

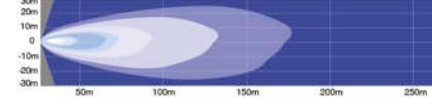

MLBMAR 84 W



1000 WATT HALOGEN EQUIVALENT
 Forward Rake Trunnion Bracket / Aiming System on Bracket / Reverse Polarity Protection

BEAM PATTERN 10°,25°,40°,60°,90°,30x65°	WARRANTY Extended	DIMENSIONS 177 x 132 x 102mm
RAW LUMENS 9,600 lm (ea)	EFFECTIVE LUMENS 6,697 lm (ea)	INCH 6.95" x 5.20" x 4.02"
WATTAGE / AMPS 84 W / 7.0 A @12V	VIBRATION RATING 60 Grms	WEIGHT 2.25 kg



MLBMAR-84-25

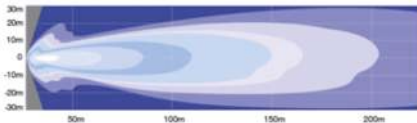

MLBMAR-84-60

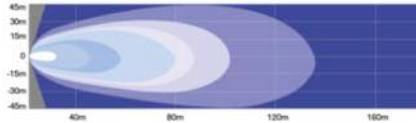

MLBMAR-84-E

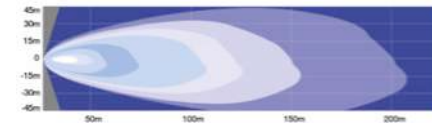

MLBMAR-84-40

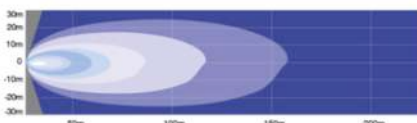

MLBMAR-84-90

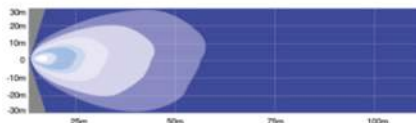

MLBMAR 63 W



700 WATT HALOGEN EQUIVALENT

Forward Rake Trunnion Bracket / Aiming System on Bracket / Reverse Polarity Protection

BEAM PATTERN 10°,25°,40°,60°,90°,30x65°	WARRANTY Extended	DIMENSIONS 154 x 132 x 85 mm
RAW LUMENS 7,200 lm (ea)	EFFECTIVE LUMENS 5,734 lm (ea)	INCH 6.08" x 5.20" x 3.33"
WATTAGE / AMPS 63 W / 5.26 A @12V	VIBRATION RATING 60 Grms	WEIGHT 1.8 kg



MLBMAR-63-25

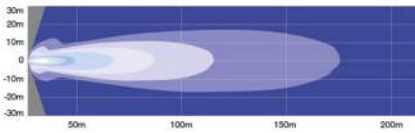

MLBMAR-63-60

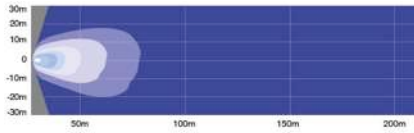

MLBMAR-63-E

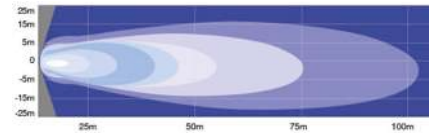

MLBMAR-63-40

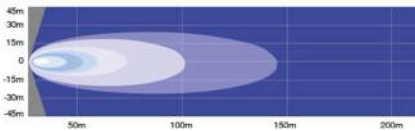

MLBMAR-63-90

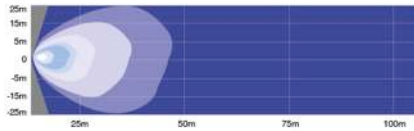

MLBMAR 35 W



400 WATT HALOGEN EQUIVALENT

Forward Rake Trunnion Bracket / Aiming System on Bracket / Reverse Polarity Protection

BEAM PATTERN 10°,25°,40°,60°,90°,30x65°	WARRANTY Extended	DIMENSIONS 123 x 112 x 101mm
RAW LUMENS 4,000 lm (ea)	EFFECTIVE LUMENS 3,305 lm (ea)	INCH 4.86" x 4.41" x 3.96"
WATTAGE / AMPS 35 W / 2.94 A @12V	VIBRATION RATING 60 Grms	WEIGHT 1.00 kg



MLBMAR-35-25

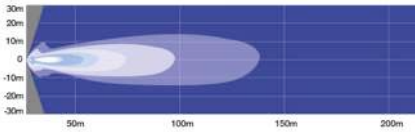

MLBMAR-35-60

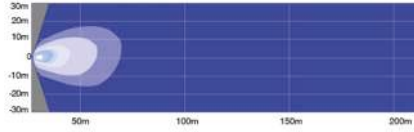

MLBMAR-35-E

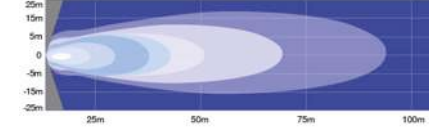

MLBMAR-35-40

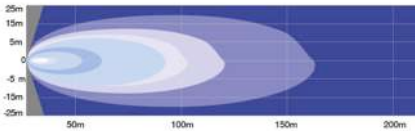

MLBMAR-35-90

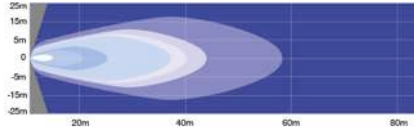



MARITIME SOLUTIONS

Maritime Lighting Series is specially manufactured to prevent effects of corrosion caused by close proximity to salt water, along with special electronics for use in or near salt water.

SOLUTION PROCESS

We create a solution for your ship or shore lighting needs while using a product specific range designed for harsh environment of saltwater. This is done through above ground copper plated circuit boards, stainless steel brackets, and a marine grade coating. Using this environment specific range to create a complete proven solution.

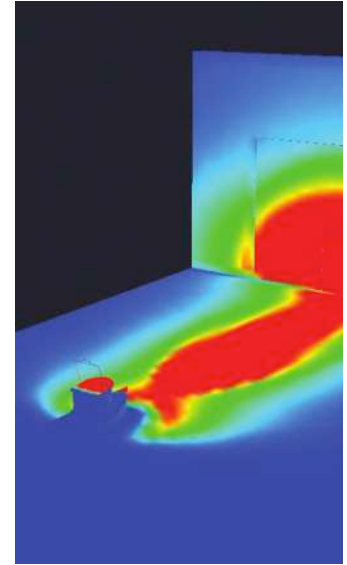
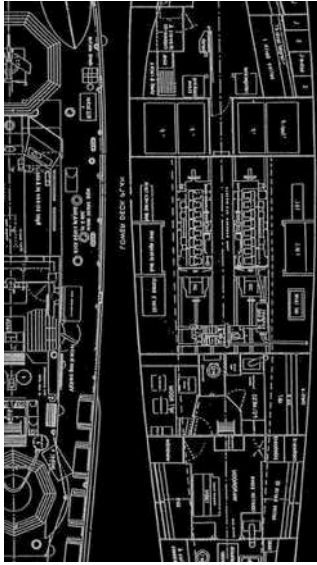

2D BLUEPRINT

We begin a project by requesting the exact areas of boat that need to be illuminated to what Lux/FC requirements.

3D MODEL

A 3D Model is then built to match the requirements requested and dropped into a realistic aquatic or port environment to ensure the light is where you need it.

SIMULATION RENDER

Prior to implementing a lighting solution, we create a simulation rendering of the intended result to help envision if the final product will meet resolve the problem.

SOLUTION

We create a solution that proves our lights are able to get you the spread and distance you need on the shore or on the ship.

FIT OUT GUIDES AVAILABLE

MERLIN TEREX MHL 380 LED KIT



- MLES-35-40-M**
35W Wide LED
Marine Coating
SUS316 Bracket
Qty 6
- 1 x Front Facing (Attached to Cabin Floor)
- 2 x Front Facing (Attached to Superstructure)
- 2 x Front Facing (Attached to Booms)
- 1 x Front Facing (Attached to Dipperstick)

MERLIN RTG LED KIT

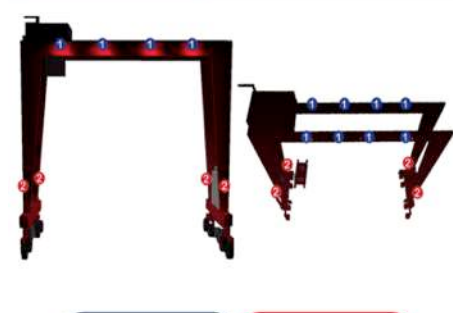

- MLP-300-60-M**
300W Extra Wide LED
Silver Line Coating
SUS316 Bracket
Qty 8 pcs
- 4x Outside of Mast Arm (Aiming Straight Down)
- 4x Outside of Mast Arm (Aiming Straight Down)
- MLP-150-60-M**
150W Extra Wide LED
Marine Coating
SUS316 Bracket
Qty 4 pcs
- 4x One on the Outside of Each Long 3.6m High Aiming Straight Down

MERLIN TXLC-976 LED KIT



- MLES-35-40-M**
35W Wide LED
Marine Coating
SUS316 Bracket
Qty 4 pcs
- 2x Rear Facing (Backup)
- 2x Rear Facing (Behind Wheel Lock)
- MLR-60-20-M**
60W Medium LED
Marine Coating
SUS316 Bracket
Qty 8 pcs
- 4x Forward Facing
- 2x Forward Facing on 4th Outboard

Merlin Equipment Pte Ltd
40 Tech Park Crescent, Singapore 638097
Tel: +65 6863 1753 Fax: +65 6863 1757
Email: sales@merlinequip.com

Merlin Equipment Pte Ltd
40 Tech Park Crescent, Singapore 638097
Tel: +65 6863 1753 Fax: +65 6863 1757
Email: sales@merlinequip.com

Merlin Equipment Pte Ltd
40 Tech Park Crescent, Singapore 638097
Tel: +65 6863 1753 Fax: +65 6863 1757
Email: sales@merlinequip.com

INDUSTRIAL MARITIME SOLUTIONS

ABOUT THE MARITIME SERIES

The Maritime Series line provides the ideal solution for watercraft of all sizes. From commercial freight ships to fishing vessels for hobbyists, we carry the perfect LED fixtures. Each electronics board used in the Maritime line is constructed from copper to remove corrosion issues typically common in saltwater applications.

Additionally, the gloss coating reduces wear from constant barrage of saltwater while at sea, ensuring the light performs day in and day out. The heavy duty stainless steel bracket combines maximum strength with a bracket that won't deteriorate over time.

Maritime products operate at a 5000 K color temperature, giving the light a warmer feel.

ABOVE GROUND MARITIME

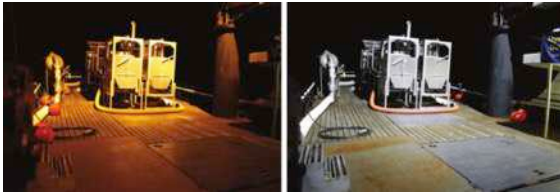

SALTWATER PROTECTION

The unique gloss coating used on Maritime products greatly reduces the dramatic impact that saltwater has on traditional lighting fixture housings.

STAINLESS STEEL BRACKET



INCLUDING MOUNTING

The each fixture in the Maritime Series comes equipped with a high-strength stainless steel bracket that gives the light extra protection against salt water corrosion.

COPPER PLATED BOARD



ANTI-CORROSION

The Maritime products feature a copper electronic board to eliminate any chance of corrosion. Additionally, the copper board helps reduce above ground CISPR.



MLP 300 W MARINE



1000 WATT METAL HALIDE REPLACEMENT LIGHT FOR MARINE APPLICATIONS
Stainless Steel Bracket / AC Versions Available / Prime Drive Technology

BEAM PATTERN 10°,20°,40°,60°,90°,30x65°	WARRANTY Extended	DIMENSIONS 383 x 293 x 175mm
RAW LUMENS 31,680 lm (ea)	EFFECTIVE LUMENS 22,200 lm (ea)	INCH 15.07" x 11.54" x 6.87"
WATTAGE / AMPS 300 W / 25 A @12V	VIBRATION RATING 60 Grms	WEIGHT 14.7 kg



BEAM PATTERN - MLP-300-60-M

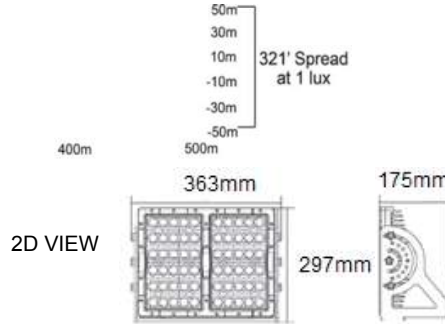
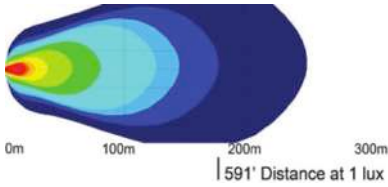

ITEM	BEAM PATTERN
MLP-300-10-M	10°, NARROW
MLP-300-20-M	20°, MEDIUM
MLP-300-40-M	40°, WIDE
MLP-300-60-M	60°, EXTRA WIDE
MLP-300-90-M	90°, EXTREM WIDE
MLP-300-E-M	30x65°, ELLIPTICAL

MLP 150 W MARINE



400/500 WATT METAL HALIDE REPLACEMENT LIGHT FOR MARINE APPLICATIONS
Stainless Steel Bracket / AC Versions Available / Prime Drive Technology

BEAM PATTERN 10°,20°,40°,60°,90°,30x65°	WARRANTY Extended	DIMENSIONS 297 x 191 x 126mm
RAW LUMENS 15,840 lm (ea)	EFFECTIVE LUMENS 11,100 lm (ea)	INCH 11.96" x 7.52" x 4.94"
WATTAGE / AMPS 150 W / 12.5 A @12V	VIBRATION RATING 60 Grms	WEIGHT 7.3 kg



BEAM PATTERN - MLP-150-60-M

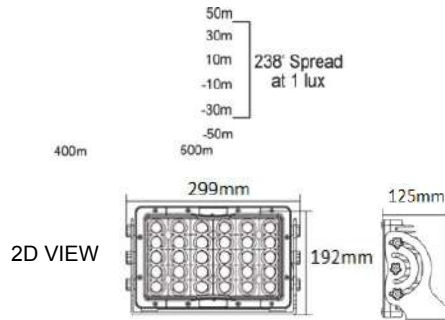
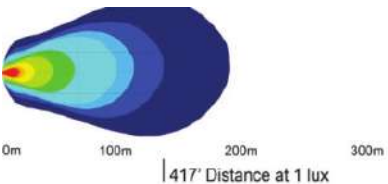

ITEM	BEAM PATTERN
MLP-150-10-M	10°, NARROW
MLP-150-20-M	20°, MEDIUM
MLP-150-40-M	40°, WIDE
MLP-150-60-M	60°, EXTRA WIDE
MLP-150-90-M	90°, EXTREM WIDE
MLP-150-E-M	30x65°, ELLIPTICAL

OTHERS MLP MARINE MODELS AVAILABLE

MLP 360 W MARINE / MLP 180 W MARINE

MLR 100 W MARINE



STAINLESS STEEL BRACKET WITH UPGRADED ELECTRONICS FOR MARINE USE
60 Grms High Vibration Rating / Single Bolt Mounting / Stainless Steel Trunnion Bracket

BEAM PATTERN 10°,20°,40°,60°,90°,30x65°	WARRANTY Extended	DIMENSIONS 177 x 168 x 102.9 mm
RAW LUMENS 10,560 lm (ea)	EFFECTIVE LUMENS 7,400 lm (ea)	INCH 6.97" x 6.61" x 4.05"
WATTAGE / AMPS 100 W / 8.34 A @12V	VIBRATION RATING 60 Grms	WEIGHT 3.8 kg



BEAM PATTERN - MLR-100-60-M

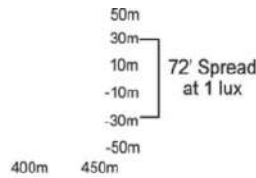
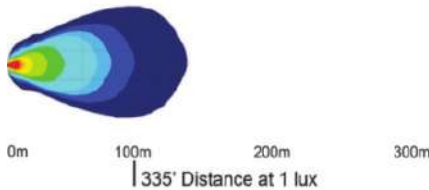

2D VIEW

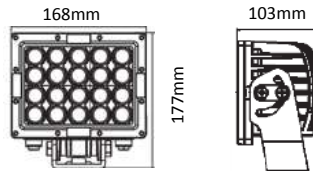

ITEM	BEAM PATTERN
MLR-100-10-M	10°, NARROW
MLR-100-20-M	20°, MEDIUM
MLR-100-40-M	40°, WIDE
MLR-100-60-M	60°, EXTRA WIDE
MLR-100-90-M	90°, EXTREM WIDE
MLR-100-E-M	30x65°, ELLIPTICAL

MLR 60 W MARINE



STAINLESS STEEL BRACKET WITH UPGRADED ELECTRONICS FOR MARINE USE
60 Grms High Vibration Rating / Single Bolt Mounting / Stainless Steel Trunnion Bracket

BEAM PATTERN 10°,20°,40°,60°,90°,30x65°	WARRANTY Extended	DIMENSIONS 176.2 x 120 x 102.9 mm
RAW LUMENS 6,336 lm (ea)	EFFECTIVE LUMENS 4,440 lm (ea)	INCH 6.94" x 4.72" x 4.05"
WATTAGE / AMPS 60 W / 5 A @12V	VIBRATION RATING 60 Grms	WEIGHT 2.5 kg



BEAM PATTERN - MLR-60-60-M



2D VIEW

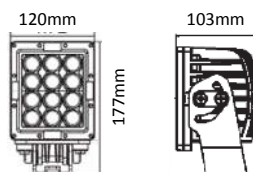

ITEM	BEAM PATTERN
MLR-60-10-M	10°, NARROW
MLR-60-20-M	20°, MEDIUM
MLR-60-40-M	40°, WIDE
MLR-60-60-M	60°, EXTRA WIDE
MLR-60-90-M	90°, EXTREM WIDE
MLR-60-E-M	30x65°, ELLIPTICAL

MLES 35 W MARINE



STAINLESS STEEL BRACKET WITH UPGRADED ELECTRONICS FOR MARINE USE
 Stainless Steel Trunnion Bracket / Single Bolt Mounting / CISPR 25 Rated For Marin Use

BEAM PATTERN 10°, 25°, 40°, 60°, 90°, 30x65°	WARRANTY Extended	DIMENSIONS 120 x 159.5 x 79.7mm
RAW LUMENS 3,696 lm (ea)	EFFECTIVE LUMENS 2,590 lm (ea)	INCH 4.71" x 6.28" x 3.14"
WATTAGE / AMPS 35 W / 2.9 A @12V	VIBRATION RATING 15.6 G rms	WEIGHT 1.81 kg



BEAM PATTERN - MLES-35-60-M

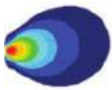

0m 100m 200m 300m
 195' Distance at 1 lux

50m
 30m
 10m } 131' Spread
 -10m at 1 lux
 -30m
 -50m
 400m 450m

2D VIEW

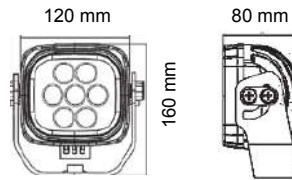

ITEM	BEAM PATTERN
MLES-35-10-M	10°, NARROW
MLES-35-25-M	25°, MEDIUM
MLES-35-40-M	40°, WIDE
MLES-35-60-M	60°, EXTRA WIDE
MLES-35-90-M	90°, EXTREM WIDE
MLES-35-E-M	30x65°, ELLIPTICAL



ACCESSORIES

MLUW 18 W



UNDERWATER LED MODULE FOR OE TRANSOM INTEGRATION
 Transom LED Light | New Model Produces Twice As Much Light | Multiple Colors Available

SUBMERSIBLE 30m	WARRANTY Extended	DIMENSIONS 105 x 105 x 33 mm
RAW LUMENS 1,336 lm (ea)	COLORS Multiple Available	INCH 4.13" x 4.13" x 1.25"



ITEM	COLOR	BEAM
MLUW-18-25-A	AMBER	25°
MLUW-18-25-B	BLUE	25°
MLUW-18-25-G	GREEN	25°
MLUW-18-25-R	RED	25°
MLUW-18-25-W	WHITE	25°



MLDL 4 W



STAINLESS STEEL BRACKET WITH UPGRADED ELECTRONICS FOR MARINE USE
 Stainless Steel Trunnion Bracket / Single Bolt Mounting / CISPR 25 Rated For Marin Use

BEAM PATTERN 180°	WARRANTY Extended	DIMENSIONS 173 x 173 x 30mm
RAW LUMENS 452 lm (ea)	EFFECTIVE LUMENS 316 lm (ea)	INCH 6.81" x 6.81" x 1.18"
WATTAGE / AMPS 4 W / 0.33 A @12V	VIBRATION RATING 8.6 G rms	WEIGHT 0.27 kg



ITEM	COLOR	BEAM
MLDL-4-180	WHITE AND RED	180°

Offering a diverse line of accent pod lighting. Easily attract attention to your vehicle with the wide variety of colors. Each durable pod accepts 9-32 volt input and features a strong black housing. Ideal for professional grade applications and weekend enthusiasts alike.



Reinforced Mounting
Each LED feature four equally distant mounting holes, allowing the light to be securely fastened to a large variety of surfaces and letting you put the light where it needs to be.

MLPP Series

LED POD PERFECT FOR ROCK LIGHTING OR COMPARTMENT LIGHTING
Impact Resistant Lens / Weatherproof Housing for All Conditions / 3" Cord



COLORS Amber, Blue, Green, Red, White	WARRANTY Extended	DIMENSIONS 45 mm diameter
RAW LUMENS 140 lm (ea)	HOUSING Aluminum	INCH 1.76" diameter

ITEM	COLOR
MLPP-A	AMBER
MLPP-B	BLUE

ITEM	COLOR
MLPP-G	GREEN
MLPP-R	RED
MLPP-W	WHITE

MLPU Series

COLORED LED LIGHTING FOR ANY APPLICATION
Impact Resistant Acrylic Lens / Weatherproof Housing for All Conditions / 10" Cord



COLORS Amber, Blue, Green, Red, White	WARRANTY Standard	DIMENSIONS 32 mm diameter
RAW LUMENS 70 lm (ea)	HOUSING Aluminum	INCH 1.25" diameter

ITEM	COLOR
MLPU-A	AMBER
MLPU-B	BLUE

ITEM	COLOR
MLPU-G	GREEN
MLPU-R	RED
MLPU-W	WHITE

MLST Series

TOUCH ACTIVATED OR STANDARD COMMERCIAL DESIGN
Universal Application / Touch Activated Model available / Compact Design



ACTIVATION MODES Touch On/Off, Hardwired	WARRANTY Standard	HEIGHT 23 mm
RAW LUMENS 141 - 328 lm (ea)	LENGTH 189 - 303 mm	DEPTH 15 mm



ITEM	MODE	COLOR
MLST-1T	Touch	189 mm
MLST-2T	Touch	303 mm

ITEM	MODE	COLOR
MLST-1H	Standard	189 mm
MLST-2H	Standard	303 mm

MERLIN[®]

40 Tech Park Crescent, Singapore 638097

Tel: +65 6863 1753 Fax: +65 6863 1757

Email: sales@merlinequip.com