



# 20W LED WORK LIGHT



## ABOUT THE MLD SERIES OEM/AFTERMARKET REPLACEMENT LIGHTING FOR HALOGEN/HID

The MLD Series gives more output than 100 Watt Halogen lights while drawing much less power and reducing wear on associated components. Additionally, the MLD Series was designed with fleet vehicles in mind, reducing cost, energy consumption, and boosting output at an attractive price.

Available in three different housing sizes and three different beam patterns, the MLD Series is one of the most adaptive fixtures. The Die-Cast Aluminium housing combines durability with afford-ability for a wide variety of applications.

## SPECIFICATION

Wattage	20 W
LEDs	4 x 5W Cree
Light Color Temp	5,700 K
Raw Lumens	2,112 lm
Voltage	9-32 VDC
Amperage	1.6 A @ 12V
Connector	Deutsch DT04-2P
Bracket Type	Trunnion
Weight	0.68 kg
Dimensions WxHxD	100 x 107 x 65 mm
IP Rating	IP69K
Vibration Rating	15.6 Grms
EMC Approval	CISPR25 Class 1 / CE Approved
Lens Material	5 mm Polycarbonate
Housing Material	Aluminum

## DIMENSIONS

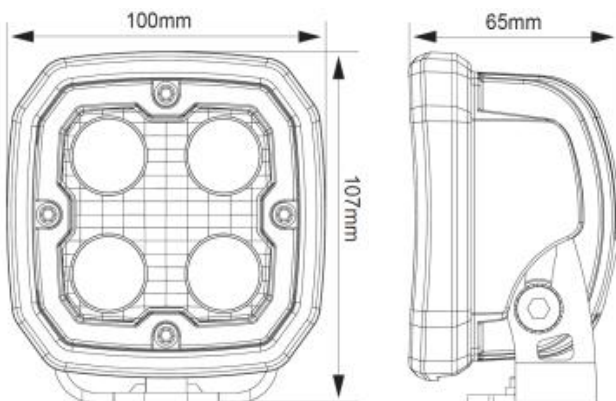

## BEAM PATTERNS

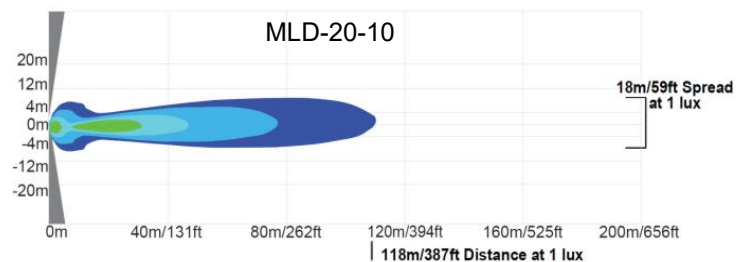

Multiple Beam Pattern Available:  
MLD-20-10, MLD-20-25, MLD-20-40, MLD-20-60,  
MLD-20-90, MLD-20-E