

HEAVY DUTY BEACON LED

DESCRIPTION

Easy add an LED Strobe beacon to your vehicle or equipment to enable others to see it from all directions. Great for Heavy Equipment's or other moving equipment, the Heavy Duty Beacon can be quickly mounted and up and running in very little time. In areas where safety is key, LED Lighting is one of the safest options for alerting someone of a dangerous piece of moving equipment.

The 18 LED Beacons come standard in a 6hz split cycle strobe pattern, meaning there's three flashes and a pause per second. When coupled with the reflectors, the heavy duty strobes become intense and are highly visible.

Features and Benefits:

- Rugged Die-Cast Aluminum Housing
- 180 LEDs Create 360° Visibility
- Amber, Red, Blue, Green or White LEDs
- Two Modes: Simulated Rotation or Flashing Functions



SPECIFICATIONS

MECHANICAL

Fixture Weight:	1.34 kg
Shipping Weight:	2.21 kg
Mounting:	Single Bolt M10

TECHNICAL

Wattage:	36 W
LED:	5050 (0.2W) / 180 LED
Color:	Amber, Red, Green, Blue
Lumens:	2,520 lm
Amp Draw:	3.0A @ 12V – 1.5A @ 24V
Operating Voltage:	12-32V DC
Operating Temp:	-40°C ~ 80°C
Lifespan:	50,000 hrs
Connector:	3 Pin Deutsch

CONSTRUCTION

Housing:	Die-Cast 6061 Aluminium
Housing Color:	Gloss Color
Lens:	Polycarbonate
Surface Mounting:	5 x 5.5mm diameter on 148mm Bolt Circle
Pole Mounting:	3/4" NPT Female Input

RATINGS

EMC Emissions:	CISPR 25 Class 1
Ingress Protection:	IP-68/IP69K
Vibration Rating:	15.6 Grms
Warranty:	3 Years

ITEM	DESCRIPTIONS
MLHDBM-36-A	AMBER HEAVY DUTY BEACON LED
MLHDBM-36-R	RED HEAVY DUTY BEACON LED
MLHDBM-36-B	BLUE HEAVY DUTY BEACON LED
MLHDBM-36-G	GREEN HEAVY DUTY BEACON LED

2D DRAWING

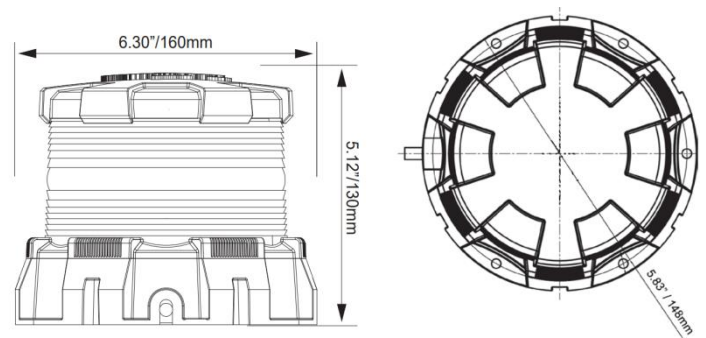

WIRING

